



PCS

3618 Series Coarse Material Washers

The Affordable Alternative in New Crushing Equipment

Gator Machinery Company specializes in designing, manufacturing and selling quarry and mining related products. The Gator PCS Coarse Material Washers are designed to complete three jobs at once, dewatering, washing and classifying. Combining the choice of either the 36" x 18' or the twin 36" x 18' model with heavy-duty tub, adjustable weir, overlapping AR shoes, AR paddles, oil bath lubricated heavy-duty gear box makes it the choice of many mining and aggregate producers.

Standard Features

- Heavy duty tub
- All welded trough minimizes leaks and extends life
- Minimal screw/tub clearance
- Ribbon type, continuous one piece auger
- Overlapping shoes and AR paddles for added auger protection
- Overflow pipe
- Greasable lower bearing assembly
- Extra heavy-duty gearbox
- 68:1 reduction ratio
- Heat treated, helical cut precision gears
- Oil bath gear box lubrication
- Standard mounting leg
- Drive belt guards

Optional Features

- Electric motor
- Motor drive sheave/Bushing
- V-belts





The Affordable Alternative in New Crushing Equipment

Specifications

Model	PCS 3618	PCST 3618
Number of screw	1	2
Screw diameter (Inches)	36	36
Tub length (Feet)	18	18
Max. feed size (Inches)	2 1/2	2 1/2
Capacity (TPH)	150 ~ 175	300 ~ 350
Screw speed (RPM)	32	32
Recommend motor (HP)	30	30 × 2
Water requirement (GPM)	400 ~ 600	700 ~ 900
Weight (LBS)	9,850	17,950
Drive Sheave (Inches)	9 5/16	9 5/16
Driven Sheave (Inches)	7 3/8	7 3/8

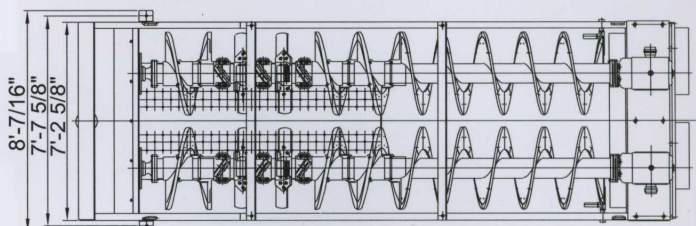
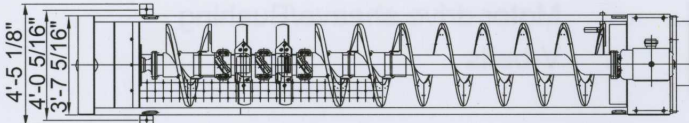
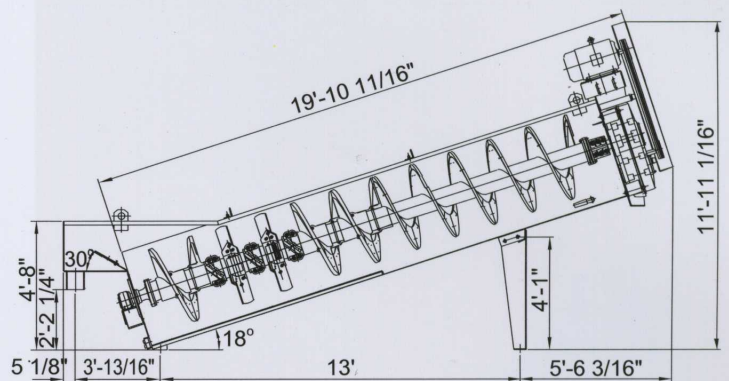
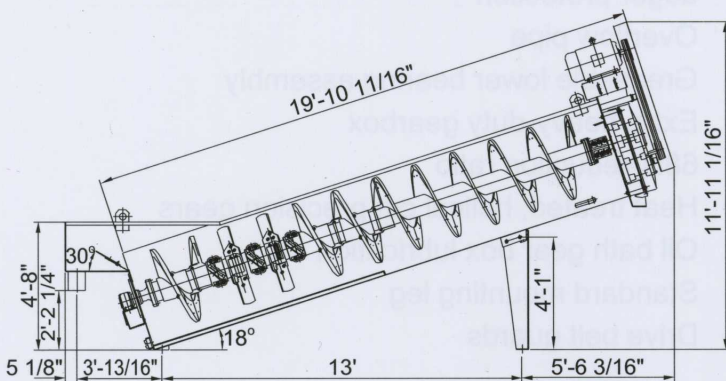

Design & Specifications Subject to Change Without Notice

November 2007

Rock Systems, Inc.

www.rocksystems.com (916) 921-9000